

MAX-TENSION™ | TANGENT, REDIRECTIVE GATING, GUARDRAIL TERMINAL
WITH SABERTOOTH™ TECHNOLOGY

- LIGHTWEIGHT, LOW PROFILE IMPACT HEAD
- AVAILABLE AS A KIT OR SYSTEM
- MASH TL-3 COMPLIANT



PHYSICAL SPECIFICATIONS

MASH Classification	TL-3, Redirective Gating	
System Length	27'	8.22 m
Effective Length	50'	15.25 m
System Width	17.5"	445 mm
Impact Head Width	5.5"	140 mm
Impact Head Weight	40 lb.	18.14 kg
Length of Need	9' 5"	2.87 m

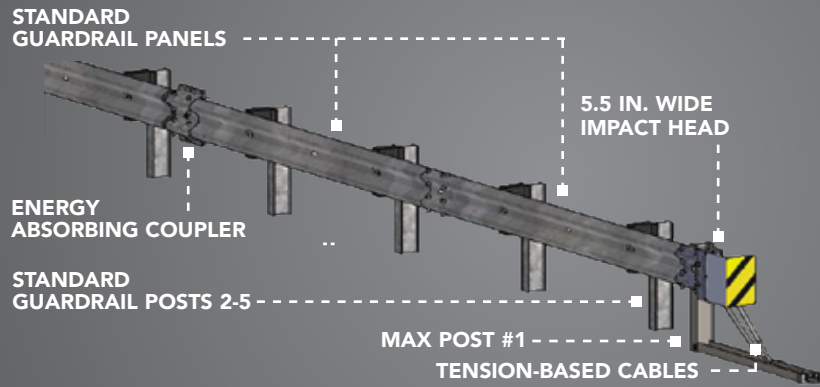

THE NEW MASH TL-3 GATING END TERMINAL

The MASH compliant MAX-Tension™ tangent end terminal, with Sabertooth™ technology, features the next level of impact performance and an ultra-slim design. The system utilizes a tension-based design along with an energy absorbing coupler that features an all new cutting tooth design. When impacted head-on, deceleration is controlled by friction developed in the tension cables and by cutting the downstream guardrail panels. When a side impact occurs, tension cables can help safely redirect a motorist away from the hazard.

In addition, the MAX-Tension terminal utilizes standard guardrail components for significant savings in inventory and maintenance costs. Nuisance impacts during snow removal and maintenance operations can also be minimized due to the narrow design of the MAX-Tension Impact Head.

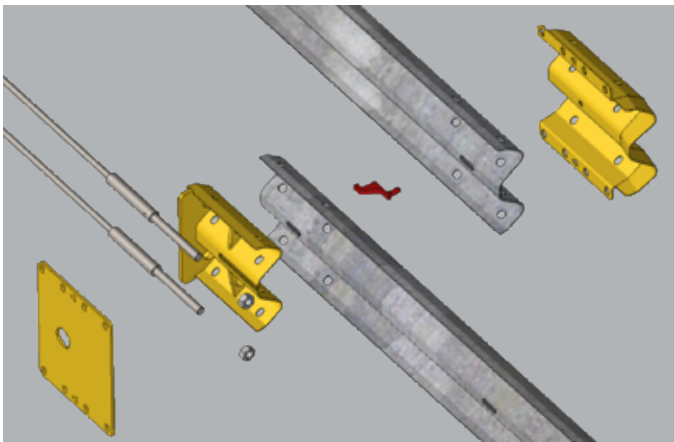

The MAX-Tension Energy Absorbing Coupler (gold) is fitted with a patent pending galvanized Sabertooth (red). When the system is impacted head-on, the Sabertooth is engineered to cut the downstream guardrail to aid in the deceleration of an errant vehicle.

FEATURES

- » Tension-based cables control deceleration and increase re-redirective performance.
- » Sabertooth technology increases energy absorbing capacity and weakens the downstream guardrail rail to help reduce the severity of impacts.
- » Lightweight impact head makes installation quick & easy.
- » Vehicle stopping distance is under 23' [7 m] (MASH 3-31).
- » Available as a kit or full system, utilizes standard guardrail panels, posts and components after post 1.

WHERE TO USE

Side of road where a recommended clear zone and recoverable slope is attainable.

DISTRIBUTED BY:



Lindsay Transportation Solutions Sales and Services, Inc.

180 River Road • Rio Vista, CA 94571 • +1 707.374.6800 U.S. Toll Free: 888.800.3691 • www.barrriersystemsinc.com

General details for the MAX-Tension Guardrail End Terminal are subject to change without notice to reflect improvements and upgrades.

Additional information is available from Lindsay Transportation Solutions Sales and Services, Inc. © Lindsay Transportation Solutions, Inc.

PT # MAX01.2-05152017